

**DETC2006-99634**

## THE OPERATION AND KINEMATIC ANALYSIS OF A NOVEL CAM-BASED INFINITELY VARIABLE TRANSMISSION

**Derek F. Lahr**

Mechanical Engineering Department  
Virginia Polytechnic Institute  
and State University  
Blacksburg, Va 24061  
email:dlahr@vt.edu

**Dennis W. Hong**

Mechanical Engineering Department  
Virginia Polytechnic Institute  
and State University  
Blacksburg, Va 24061  
email:dhong@vt.edu

### ABSTRACT

In this paper, the operation and analysis of a novel, highly configurable, infinitely variable transmission of the ratcheting drive type is presented. This particular drive uses a cam and a number of cam followers rotatably mounted to a carrier plate to generate an oscillatory motion in an equal number of planet gears. A number of indexing clutches are then used to rectify this motion into a rotational output. A full description of the mechanism, including its components, operation, and kinematic equations are presented. There are a number of inversions of this device, and their characteristics and limitations are discussed. In addition, a method is presented to select the most suitable inversion, gearing, and follower velocity for a given application.

### INTRODUCTION

A continuously variable transmission (CVT) is a system which allows a user to vary the speed between an input and output progressively from one positive value to another. Unlike conventional transmissions, the selection of gears is not restricted to a finite number of ratios. An infinitely variable transmission (IVT) is a CVT which can also achieve a transmission ratio of zero. Presented here is a novel, highly configurable, ratcheting IVT based on a cam and a planetary gearset. It is unique in both its operation and its possible applications because it combines the flexibility of a planetary gearset and an IVT into one mechanism. Unlike other ratcheting IVTs which produce a nonuniform output for a uniform input [1-5], this transmission has the unique ability to produce a continuous and uniform output, and can even shape the output to match a periodic waveform.

Currently, IVTs are used in automotive and industrial drive applications to improve performance, economy and functionality. As fossil fuel prices rise, and oil wells dry up [6], the world is turning towards renewable energy sources for relief.

It is in this sector that an IVT can have an especially large impact on productivity, specifically, as transmissions for variable speed wind turbines. These are the latest generation in wind turbine technologies which, as the name suggests, allow the turbine rotor to spin at variable speeds in accordance with wind speed fluctuations. Therefore, the rotors operate at maximum aerodynamic efficiency at all times, producing 10% more energy per year [7]. Current variable speed wind turbine designs use expensive power electronics to convert a variable AC power to the constant voltage and frequency necessary for the nation's electrical grid. Replacing these electronics with a mechanical transmission can significantly decrease the cost, up to 6.8% [8]. In addition, an IVT can reduce the fatigue loads on the rotors from wind gusts and allow more reliable generators to be used to eliminate the maintenance prone slip rings in conventional variable speed generators, both significant causes of machine failure. Therefore, this is an application in which the cam-based IVT is particularly well suited.

### NOMENCLATURE

$a$ , maximum level of follower acceleration;  
 $F_n$ , contact force between roller and cam;  
 $n$ , number of followers;  
 $r_3$ , sun gear radius;  
 $r_a, r_b$ , gear radii;  
 $r_p$ , planet gear radius;  
 $R_f$ , vector along length of follower;  
 $\theta_1$ , angular position of the cam;  
 $\theta_2$ , angular position of the carrier;  
 $\theta_3$ , angular position of the sun gear;  
 $\theta_L$ , magnitude of follower lift during acting profile;  
 $\theta_p$ , angular position of the follower and planet gear;  
 $T_{in}$ , input torque;

- $v_n$ , normal vector to surface of cam at the point of contact;
- $\omega_1$ , angular velocity of the cam;
- $\omega_2$ , angular velocity of the carrier;
- $\omega_3$ , angular velocity of the sun gear;
- $\omega_p$ , relative angular velocity of the followers and planet gears with respect to the phase angle of the cam;
- $(x_r, y_r, z_r)$ , coordinates of the roller center;
- $(x_c, y_c, z_c)$ , coordinates of contact point between roller and cam;

## BACKGROUND AND PREVIOUS WORK

There is a substantial amount of prior work in the field of infinitely variable transmissions. These drives can be separated into 4 different categories [9]: traction, belt, ratcheting, and hydrostatic drives. Traction drives transmit power through rotating wheels in contact, such as the torroidal drives seen in the automotive industry. These transmissions have been limited by the high contact force necessary between the rotating elements [10]. Belt drives are similar to traction drives but use a pair of movable sheaves and belt to transmit power. They too suffer from the same difficulties of the traction drives, high forces between the sheaves and belt, and also from high pumping losses in their hydraulic systems [10].

The ratcheting drive type takes a rotational input, converts it to an oscillating motion of varying amplitude, and then rectifies this motion through a number of one way clutches to a rotational output.

The prior work in ratcheting drives includes that by Benitez. He presents a transmission whose operation is similar to the concept presented here, but it is characterized by its non-uniform output for a uniform input [1,2]. It is similar in that there is a device which varies the amount of rotation of several planetary gears with respect to the carrier. This particular design uses a slotted plate with varying eccentricity. Similarly, Pires [3,4] incorporates a number of levers, shafts, and a slotted plate to accomplish the same task. Clutches are then used to transmit power from the gear with the greatest rotational velocity. Similar in concept to both Pires and Benitez, but different in implementation, is the design by Matsumoto [5]. This transmission uses several reciprocating four bar linkages to oscillate the indexing clutches. Like Benitez's though, it exhibits a non-uniform output for a uniform input.

The cam-based IVT is advantageous in several ways when compared to these transmissions. It can be designed to produce a uniform output given a uniform input, but unlike any of these ratcheting drives, its output can also be matched to nearly any periodic waveform as well.

## THEORY OF OPERATION

### Components

In its simplest form, this transmission contains five primary components. The heart of this transmission is a centrally located, three dimensional camoid. Around the cam are a number of followers, rotatably mounted to a carrier plate. Spherical rollers can be used at the follower end to reduce friction, although they are not pictured in Figure 1. The carrier

rotates around the central axis of the cam, causing the followers to orbit around the cam. Each of these followers is fixed to a planet gear. There exist an equal number of sun gears, each meshed to one of the planet gears. All the sun gears are connected to the output shaft through an indexing clutch.

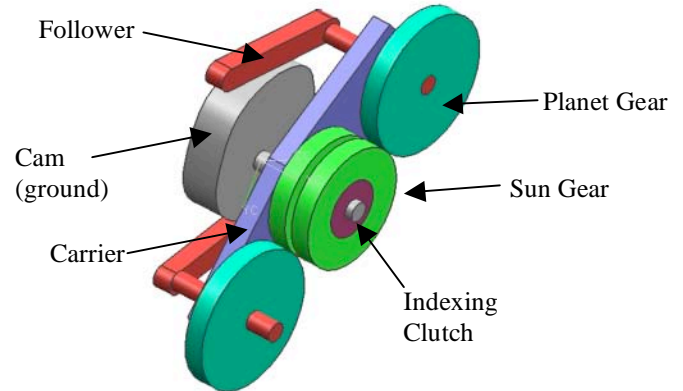

Figure 1: Simplified portrayal of the Cam-based IVT.

### Operation

In its simplest inversion, a rotational input to the carrier causes the carrier to rotate about the cam. The followers, moving around the cam with the carrier, will then oscillate as they move up and down the lobes of the cam with the help of a return spring. Because the followers are located at different positions around the cam profile, their oscillations will be out of phase. Each of the planet gears, attached to a follower, will then rotate back and forth. Here the operation is similar to a planetary gearset, where the rotation of the sun gear depends both upon the carrier and the planet gear rotations. In this transmission, the oscillations of the sun gear due to the planet gear are superimposed upon the forward rotation of the sun gear due to the carrier. As the individual sun gears oscillate, they will periodically engage and disengage the output shaft through the indexing clutches. Because the followers are out of phase, and therefore the sun gear oscillations are out of phase, the output of the transmission will always be in the same direction.

Like a planetary gearset, the input and output of this transmission can be selected between the cam, carrier, or sun gear. The unique characteristics of each inversion can be matched to the particular application. For instance, several inversions are continuously variable while others are infinitely variable. In addition, this transmission can be designed as a differential device with either two inputs or two outputs. All inversions though are operationally similar to that described above.

### Shifting

By stacking an infinite series of profiles along the length of the cam to make a three dimensional camoid, an infinite number of transmission ratios can be selected. By varying the

position of the cam followers in relation to the cam, the particular profile they follow can be changed. This affects the magnitude of the follower's oscillations and therefore the transmission output.

While shifting, to move either the cam or the followers under load, would require the shifter to overcome the high static friction between the roller and the cam. In addition, as a follower moves across the cam, it will also rotate as it moves onto a larger lobe. If this rotation is in the same direction required to activate the indexing clutches, the followers will then be transmitting torque to the output, and therefore part of the shifting load will be required to drive the output. A unique advantage of a ratcheting drive though, is that the followers are unloaded on a portion of the cam. This allows them to be repositioned with less force, and therefore, the shifting mechanism must only overcome the friction between the roller and the cam produced by the return spring. As the follower then enters the active profile of the cam, it will produce a different transmission ratio. A more complete model of the transmission including the three dimensional camoid and a proposed shifter can be seen in Figure 2. In this model though, the indexing clutches have been moved to the planet gears, such that only one sun gear is necessary.

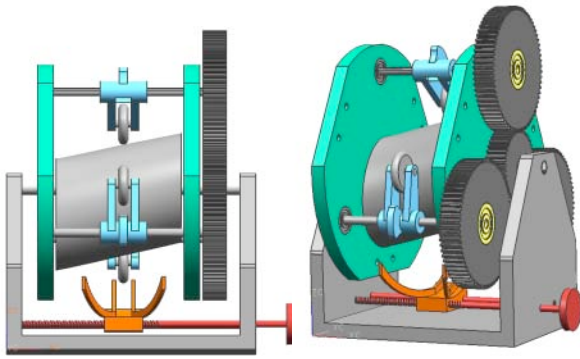

Figure 2: The front and isometric view of the transmission.

### Inversion Characteristics

As stated, this transmission can be used in several different inversions. The input and output can be varied between the sun gear, planet carrier, or cam. For some inversions, the ratio range is limited by the direction of the overrunning clutches, such that it may be impossible to achieve all ratio between minus infinity and plus infinity. The characteristic ratio range for each of the inversions can be seen in Table 1, which was found by inspection of the mechanism. For example, take the sun gear as the input, and the cam as the output. As a torque is applied to the sun gear, it forces the followers down onto the cam. The cam could then rotate as the followers roll down the slope to the smaller radius of the cam. But at this point, to return to their original position, the followers must rotate in the opposite direction, the direction in which the indexing clutches transmit motion, thereby preventing any motion of the follower.

The selection of the inversion will therefore depend on the required ratio range of the transmission. In addition, the internal stresses are different for each inversion, and may further limit the possible applications.

Table 1. Possible ratio range of the various inversions.

Input	Output	Ratio range
cam	carrier	-inf, 1
cam	sun gear	-inf, inf
sun gear	carrier	1, inf
sun gear	cam	not possible
carrier	cam	0, 1
carrier	sun gear	-inf, 0

### KINEMATIC ANALYSIS OF THE CAM-BASED IVT

The behavior of the transmission is completely dependent on the cam profile. In this section, the behavior of the transmission is described in terms of an arbitrary profile, which for reference can be seen in Figure 3. Several variables can be assigned which will help define the behavior of the transmission.

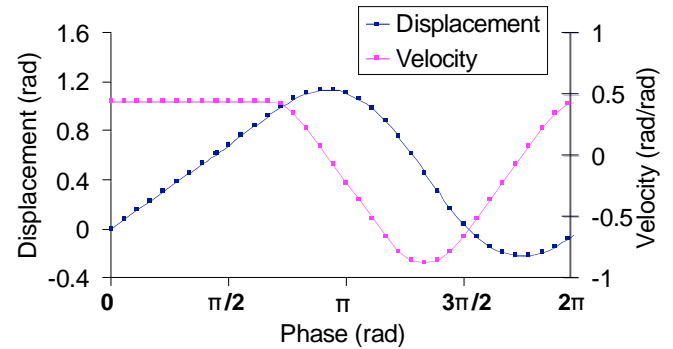

Figure 3: Displacement profile of an arbitrary cam profile.

The acting planet is the planet gear with the maximum rotational velocity at any time and is the gear that is driving the output. The portion of the cam profile on which a follower, and therefore planet gear, has the maximum velocity is called the acting profile. The lift of the follower,  $\theta_L$ , during the acting profile of the cam is given by:

$$\theta_L = \frac{\pm \int_0^{2\pi} \max(\omega_{p1}(\theta_2), \omega_{p2}(\theta_2), \dots, \omega_{pn}(\theta_2)) d\theta_2}{n}, \quad (1)$$

where  $\omega_p$  is the velocity of the planet gear. This is illustrated in Figure 4 which shows  $n$  velocity profiles overlaid with an offset of  $2\pi/n$ . In this example,  $n$  equals three for a transmission with three followers. The sign of  $\theta_L$  is positive if the follower rotates in the same direction of the cam as it rotates and is negative if they rotate in opposite directions. When the follower velocity is constant for the acting profile, Equation 1 simplifies to:

$$\theta_L = \pm \max(\omega_p(\theta_2)) \frac{2\pi}{n}. \quad (2)$$

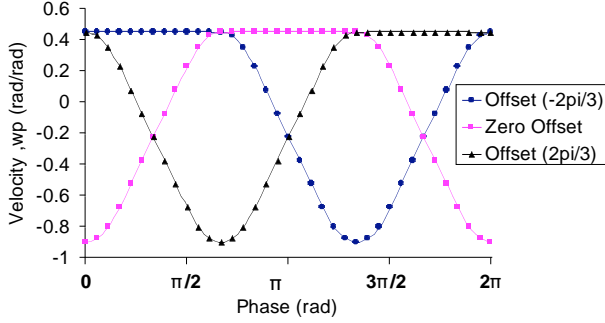
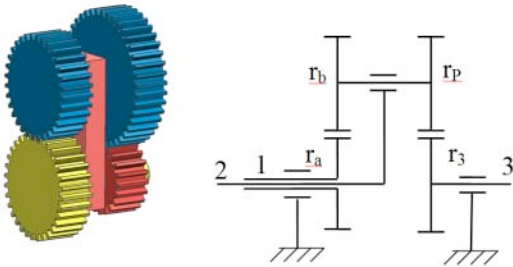

**Figure 4: Overlay of the velocity profile in Figure 3 for three velocity profiles, showing the transfer of power between followers.**

A kinematic relationship for this IVT can be established for any velocity profile, but this design assumes a constant velocity output. To derive the kinematic equation for the entire transmission, we can apply the analogy presented earlier of a planetary gearset, as seen in Figure 5. The kinematic relationship of the gearset presented below is as given in Equation 3:

$$\theta_3 = \theta_2 \left( 1 - \frac{r_a r_p}{r_b r_3} \right) + \theta_1 \frac{r_a r_p}{r_b r_3}, \quad (3)$$

where  $\theta_1$ ,  $\theta_2$ , and  $\theta_3$  denote the angular position of the first sun, carrier, and second sun respectively, and  $r_a$ ,  $r_b$ ,  $r_p$ , and  $r_3$  denote the radii of the gears as presented in Figure 5. The relationship expressed in Equation 3 can be modified by replacing the gear ratio of one pair of sun and planet gears with an effective gear ratio between the followers and the cam.



**Figure 5: Planet gearset representative of the Cam-based IVT.**

This effective ratio is essentially the collective amount the followers rotate in one direction for every revolution about the cam and is therefore analogous to the gear ratio  $r_a/r_b$  in Equation 3. It is given by Equation 4:

$$EffectiveRatio = \frac{\theta_L n}{2\pi}. \quad (4)$$

The relationships presented in Equation 3 and 4 can be expressed as Equation 5, where  $\theta_1$  now represents the angular position of the cam:

$$\theta_3 = \theta_2 \left( 1 - \frac{\theta_L n r_p}{2\pi r_3} \right) + \theta_1 \frac{\theta_L n r_p}{2\pi r_3}, \quad (5)$$

Differentiating Equation 5 yields:

$$\omega_3 = \omega_2 \left( 1 - \frac{\theta_L n r_p}{2\pi r_3} \right) + \omega_1 \frac{\theta_L n r_p}{2\pi r_3}. \quad (6)$$

Equation 6 can be used for any inversion of the transmission where the corresponding velocity of the stationary component is set to zero.

### CAM PROFILE DESIGN

The cam profile was designed using a trapezoidal acceleration curve. This curve includes a portion of zero acceleration, to produce the constant velocity output, and a trapezoidal portion required for the return of the follower. For the trapezoidal sections, the length of the upslope was half the duration of the horizontal portion to keep jerk levels to an acceptable level [11]. The velocity and position equations presented in Table 2 were found from the integration of the acceleration curve.

Subsequently, the actual level of acceleration needed to return the follower to its origin after the acting profile was found. The magnitude of this acceleration is a function both the number of followers,  $n$ , and the relative velocity of the followers,  $\omega_p$ . Once the number of followers was determined for the specific transmission, the equations from Table 2 were programmed into Microsoft Excel and the acceleration,  $a$ , for an arbitrary value of  $\omega_p$  was found numerically. Knowing that  $a=0$ , when  $\omega_p=0$ , all other values of acceleration can then be linearly interpolated from these two points.

The exact position and velocity curves of the cam follower can be established from this level of acceleration. A set of normalized curves can be seen in Figure 6.

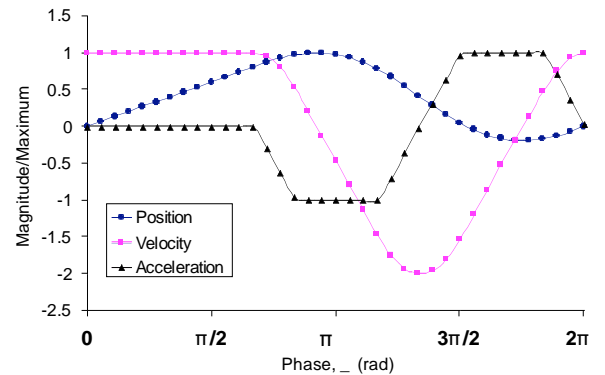
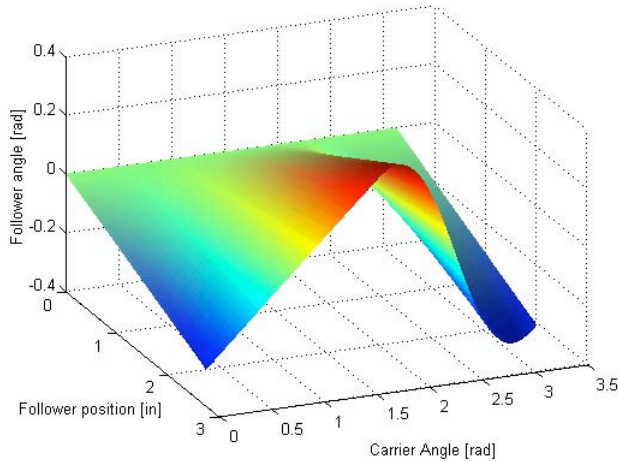

**Figure 6: The follower's acceleration, velocity, and position as a function of cam rotation.**

**Table 2. Acceleration, Velocity, and Position functions for a transmission having  $n$  followers.**

Phase, $\theta_2$	Acceleration, $A$	Velocity, $\omega_p$	Position, $\theta_p$
$[0, 2\pi/n]$	0	$\omega_p$	$\omega_p \theta_2 + \theta_p(0)$
$[2\pi/n, b]$ , where $b = \pi(n+7)/4n$	$-\frac{2n \cdot a(\theta_2 - \frac{2\pi}{n})}{\pi}$	$-\frac{n \cdot a(\theta_2 - \frac{2\pi}{n})^2}{\pi} + \omega_p(\frac{2\pi}{n})$	$-\frac{n \cdot a(\theta_2 - \frac{2\pi}{n})^3}{3\pi} + \omega_p(\frac{2\pi}{n})(\theta_2 - \frac{2\pi}{n}) + \theta_p(\frac{2\pi}{n})$
$[b, c]$ , where $c = \pi(3n+5)/4n$	$-a$	$-a(\theta_2 - b) + \omega_p(b)$	$-\frac{a(\theta_2 - b)^2}{2} + \omega_p(b)(\theta_2 - b) + \theta_p(b)$
$[c, d]$ , where $d = \pi(5n+3)/4n$	$\frac{2n \cdot a(\theta_2 - c)}{\pi} - a$	$\frac{n \cdot a(\theta_2 - c)^2}{\pi} - a(\theta_2 - c) + \omega_p(c)$	$\frac{n \cdot a(\theta_2 - c)^3}{3\pi} - \frac{a(\theta_2 - c)^2}{6} + \omega_p(c) \cdot (\theta_2 - c) + \theta_p(c)$
$[d, e]$ , where $e = \pi(7n+1)/4n$	$a$	$a(\theta_2 - d) + \omega_p(d)$	$\frac{a(\theta_2 - d)^2}{2} + \omega_p(d) \cdot (\theta_2 - d) + \theta_p(d)$
$[e, 2\pi]$	$-\frac{2n \cdot a(\theta_2 - e)}{\pi} + a$	$-\frac{n \cdot a(\theta_2 - e)^2}{\pi} + a(\theta_2 - e) + \omega_p(e)$	$-\frac{n \cdot a(\theta_2 - e)^3}{3\pi} + \frac{a(\theta_2 - e)^2}{6} + \omega_p(e) \cdot (\theta_2 - e) + \theta_p(e)$

The cam is designed such that  $\omega_p$  increases linearly along its lengths, and therefore, the magnitude of the follower motion increases linearly as well, which generates the ruled surface seen in Figure 7. From this surface, the cam shape can be found using either the envelope theory for two surfaces [12], or the point of contact theory [13].



**Figure 7: Follower position versus the carrier angle and the follower position along the length of the cam.**

### Parametric Study

Several parametric relationships were established during the design process, with the goal of reducing the contact force and therefore stress between the roller and the cam surface. If the final gear range is predetermined going into the design, the designer has the ability to manipulate either the gear ratio,  $r_p/r_s$ , or the maximum follower velocity,  $\omega_p$  to meet this objective.

To study the relationship between these variables and the contact force, an orthogonal coordinate system is established

such that the  $z$  direction is parallel to the follower axis of rotation and the  $x$  axis parallel to a line at  $\theta_2=0$ . It is necessary to know the unit normal vector to the surface of the cam at the contact point. Because the roller is spherical and therefore tangent to the cam surface at the contact point, this vector is the ray from the contact point to the center of the follower, as in Equation 7:

$$\vec{v}_n = (x_r - x_c)\hat{i} + (y_r - y_c)\hat{j} + (z_r - z_c)\hat{k}, \quad (7)$$

where the subscript “r” denotes the roller center point, and “c” the contact point. Defining  $\vec{R}_f$  as the vector along the length of the follower, from its pivot to the roller center, will then reflect the position of the follower with respect to the carrier,  $\theta_p$ , in the following equation. Applying a torque balance to the follower in the  $\hat{k}$  direction yields Equation 8:

$$\frac{T_{in} r_p}{r_s} = (\vec{R}_f \times \vec{v}_p) \cdot F_n \hat{k}, \quad (8)$$

where  $r_p/r_s$  is adjusted such that the maximum gear ratio is attained for the specific  $\omega_p$ , and  $T_{in}$  is applied to the sun gear. Rearranging Equation 8 yields Equation 9:

$$F_n = \frac{T_{in} r_p}{r_s (\vec{R}_f \times \vec{v}_p) \cdot \hat{k}}. \quad (9)$$

The follower angle,  $\theta_p$ , was varied between 0.6 and 1.6 radians, and the follower velocity was varied between 0.2 and 0.5 while the gear ratio,  $r_p/r_s$ , was adjusted to achieve an overall transmission ratio of three. The resulting contact force for an input torque of 86 [ft-lbs] can be seen in Figure 8.

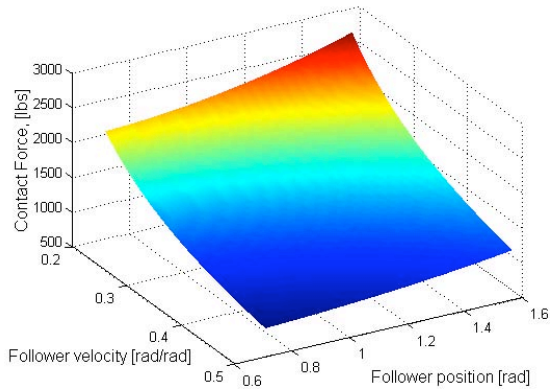

**Figure 8: Contact force between roller and cam.**

What is significant about Figure 8 is that increasing  $\omega_p$  while adjusting  $r_p/r_s$ , will result in a lower contact force. In addition, at the lower values of  $\theta_p$ , the contact force is reduced. Therefore, at the maximum gear ratio, it is best to operate the follower at small levels of  $\theta_p$ . Although, as the follower velocity is increased, it will necessitate higher levels of acceleration and stronger return springs, and at a certain level, undercutting of the cam will result from the high follower acceleration. Therefore, this will limit the maximum usable follower velocity. When not at the maximum gear ratio, the trend is reversed, such that the pressure angle is reduced by operating at higher levels of  $\theta_p$ .

## PROTOTYPE AND TESTING

A prototype was fabricated to further test the concept and can be seen in Figure 9. This design was made from carbon fiber and aluminum, and had three operating speeds, 1:1, 1:1.3, and 1:1.6. Shifting though is accomplished only by hand. This design has worked both as a demonstration device and a test bed for design concepts such as the shifting mechanism. We have been able to verify the kinematic equations derived in this paper.



**Figure 9: Demonstration and testing prototype**

A second prototype currently being designed will be tested for efficiency, durability, stress levels, and overall operability. This design will also incorporate several design improvements aimed at increasing the available gear range and torque capacity.

## CONCLUSIONS

In this paper, the operation and analysis of a novel, highly configurable, infinitely variable transmission of the ratcheting

drive type was presented. Because this mechanism's structure and operation is similar to a planetary gearset, it is both highly flexible and has the unique ability among ratcheting drives to produce a uniform output. A full description of the mechanism, including its components, operation, and kinematic equations was presented. All of the inversions of this device, and their characteristics and limitations were discussed. In addition, a method was presented to select the most suitable inversion, gearing, and follower velocity for a given application. The cam-based IVT offers a promising solution in applications where other IVTs have failed.

## REFERENCES

- [1] Benitez, F. G., Madrigal, J. M., del Castillo, J. M., 2004, "Infinitely Variable Transmission of Ratcheting Drive Type Based on One-way Clutches", *Journal of Mechanical Design*, **126**, pp. 673-682.
- [2] Benitez, F. G., Gutierrez, J., Campillo, G., Madronal, P., 2002, "Variable Continuous Transmission System," US Patent 6,371,881.
- [3] Fitz, F. A., Pires, P. B., 1991, "A geared infinitely variable transmission for automotive applications," SAE paper no. 910407, pp. 1-7.
- [4] Pires, P. B., 2001, "Transmission Ratio Changing Apparatus and Method," US Patent 4,983,151.
- [5] Matsumoto, S., Inoue, N., Tsukada, Y., 2003, "Continuously variable transmission for bicycles," United States Patent Application 20030221892.
- [6] Deffeyes, K. S., 2005, *Beyond Oil*, Hill and Wang, New York.
- [7] Carlin, P., Laxson, A., Muljadi, E., 2001, "The History and State of the Art of Variable-Speed Wind Turbine Technology," NREL/TP-500-28607.
- [8] Cotrell, J., 2004, "Motion Technologies CRADACRD-03-130: Assessing the Potential of a Mechanical Continuously Variable Transmission," NREL/TP-500-36371.
- [9] Gott, P. G., 1991, "Changing Gears, The development of the Automotive Transmissions," SAE.
- [10] Kluger, M. A., Long, D. M., 1999, "An overview of Current Automatic Manual and Continuously Variable Transmission Efficiencies and Their Projected Future Improvement," SAE.
- [11] Rothbart, H. A., 2004, *Cam Design Handbook*, McGraw-Hill, New York.
- [12] Tsay, D. M., Hwang, G. S., 1994, "The Profile Determination and Machining of Camoids with Oscillating Spherical Followers," *Journal of Engineering for Industry*, **116**, pp. 355-362.
- [13] Chakraborty, J., Ghande, S. G., 1977, *Kinematics and geometry of planar and spatial cam mechanism*, John Wiley & Sons, New York.